

SC2 EXTERIOR SUN CONTROL DEVICES

SC2-00

FIRESTONE METAL PRODUCTS IS A CUSTOM FABRICATOR OF LAMINATED ALUMINUM SUNSCREEN SYSTEMS. THE ENCLOSED DETAILS REPRESENT THE MOST COMMONLY FABRICATED SUNSCREEN SYSTEMS. CONTACT FIRESTONE METAL PRODUCTS FOR CUSTOM FABRICATION REVIEW.

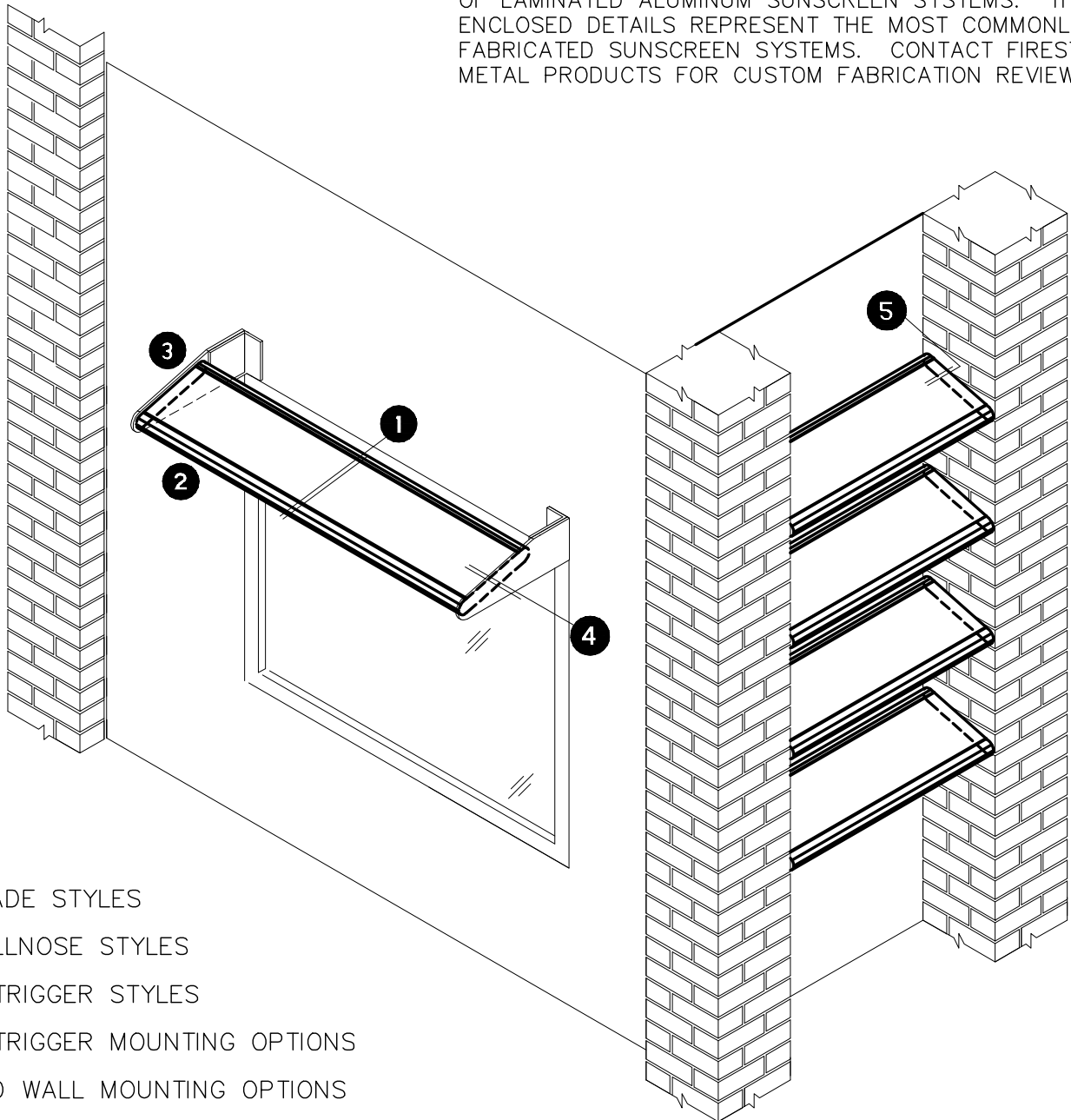

- 1 BLADE STYLES
- 2 BULLNOSE STYLES
- 3 OUTRIGGER STYLES
- 4 OUTRIGGER MOUNTING OPTIONS
- 5 END WALL MOUNTING OPTIONS
- 6 OUTRIGGER BRACKET OPTIONS
- 7 OUTRIGGER WALL ATTACHEMENT OPTIONS

REVISED 10/2009

SC2 BLADE STYLES **SC2-01**

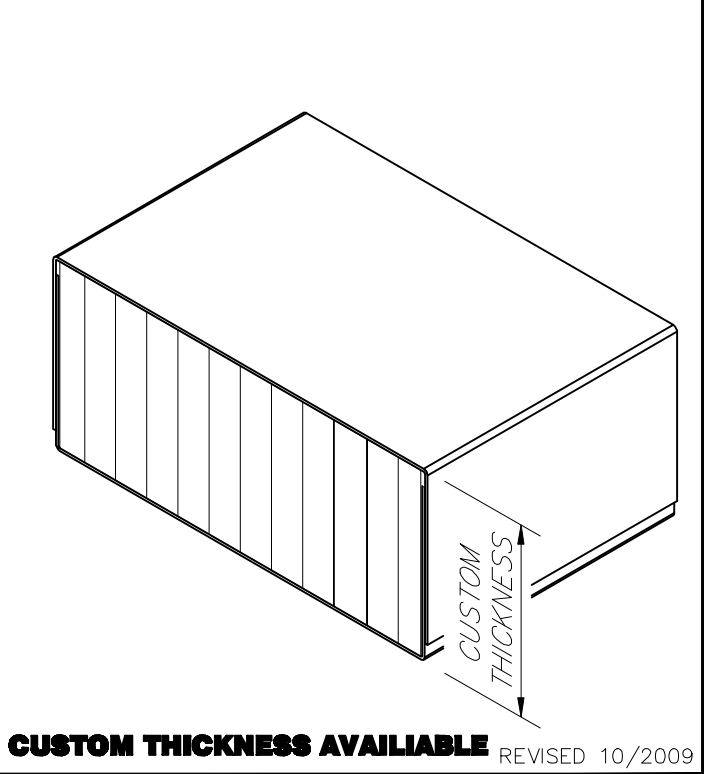
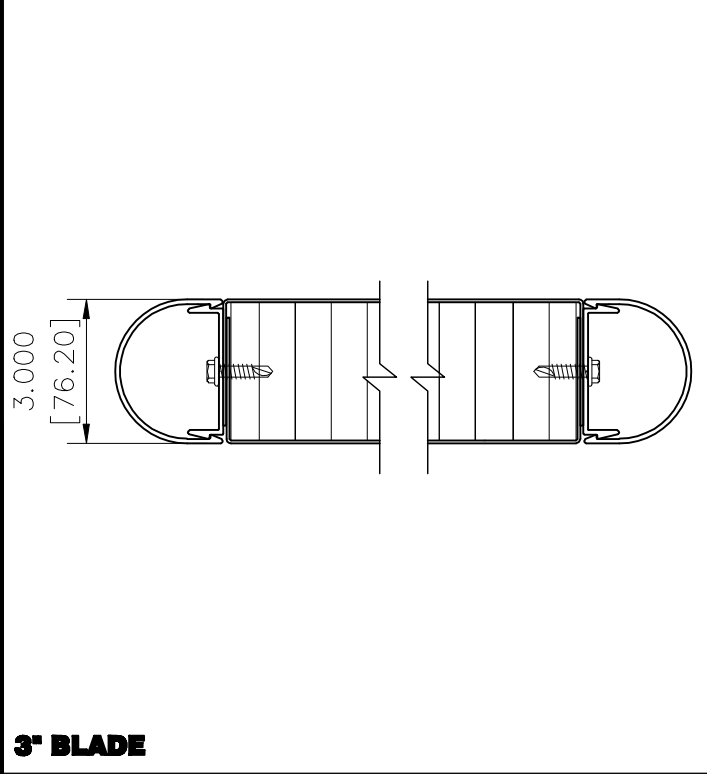
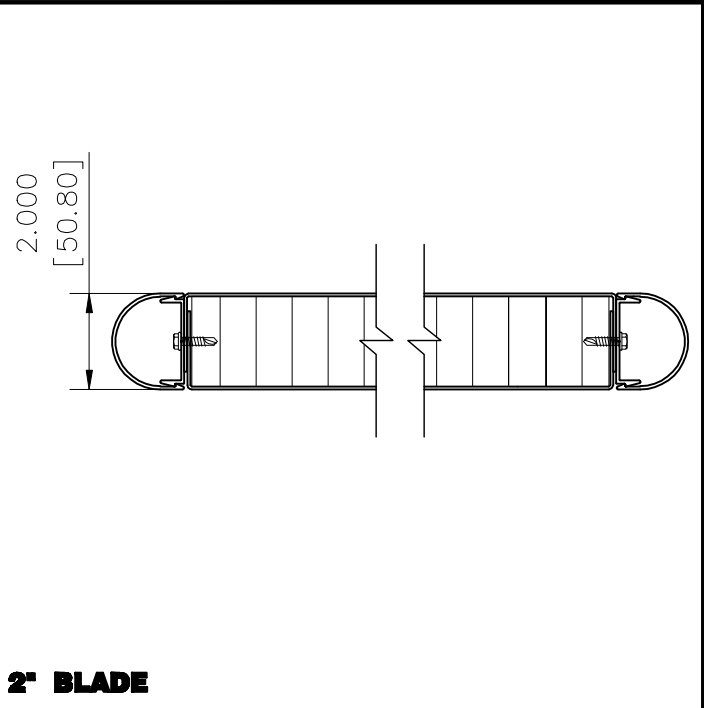
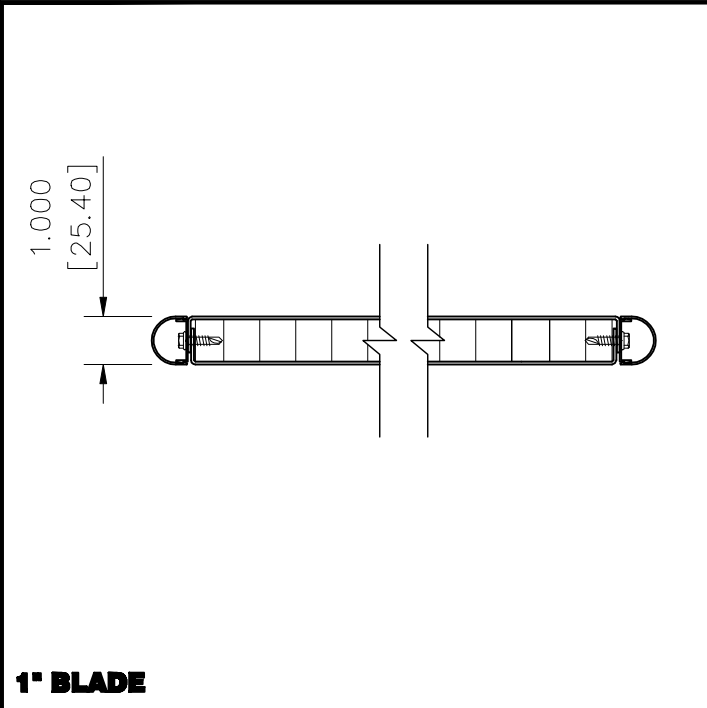

REVISED 10/2009

SC2 BULLNOSE STYLES SC2-02

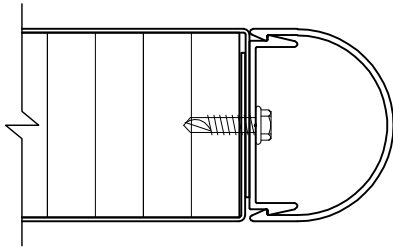

ROUND BULLNOSE FASCIA

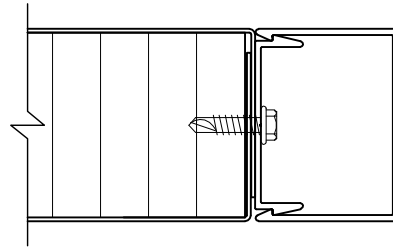

SQUARE BULLNOSE FASCIA

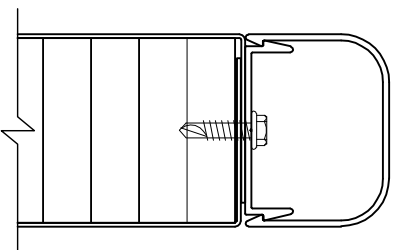

RADIUSED BULLNOSE FASCIA

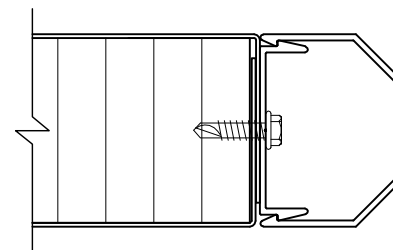

BEVEL BULLNOSE FASCIA

REVISED 10/2009

SC2 OUTRIGGER STYLES

SC2-03

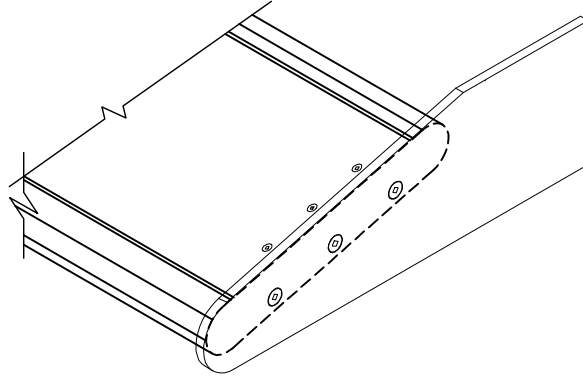

TAPERED PLATE OUTRIGGER

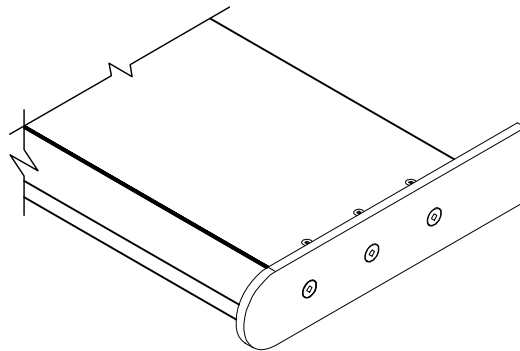

STRAIGHT PLATE OUTRIGGER

CUSTOM SHAPES AVAILABLE FOR PLATE OUTRIGGERS.
CONTACT FIRESTONE METAL PRODUCTS WITH CUSTOM
SHAPE REQUESTS.

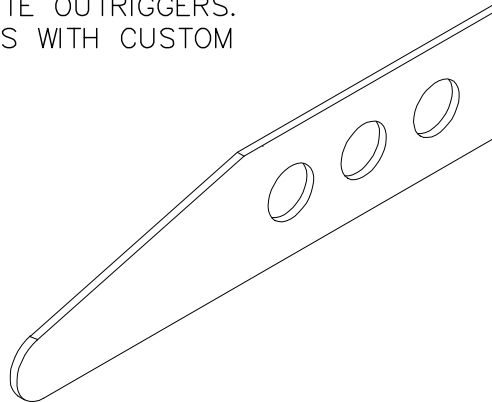

CUSTOM PLATE OUTRIGGER

REVISED 10/2009

SC2 OUTRIGGER MOUNTING OPTIONS SC2-04

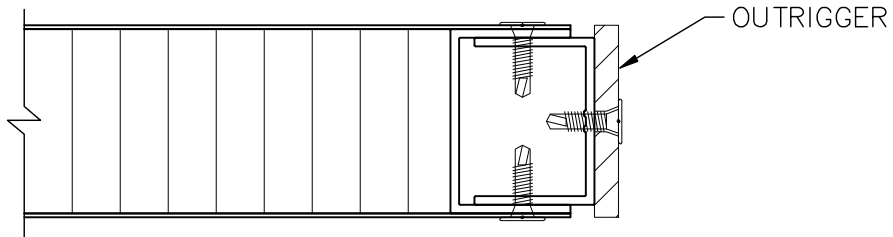

CONCEALED OUTRIGGER MOUNTING BRACKET

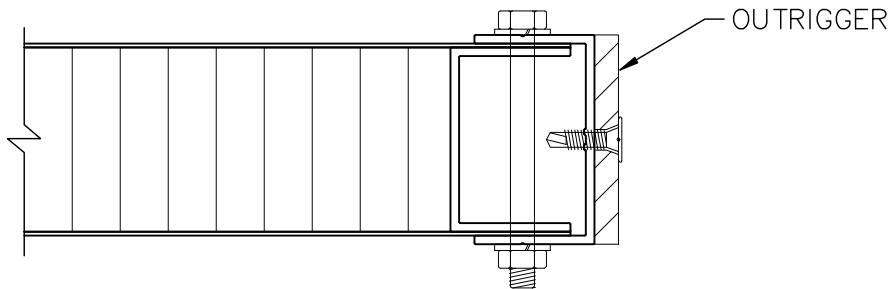

STANDARD OUTRIGGER MOUNTING BRACKET

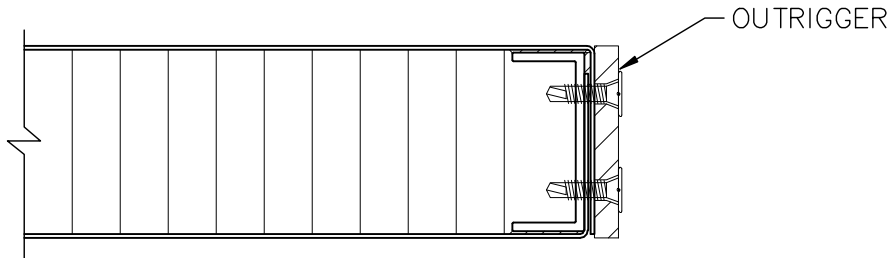

ANGLE OUTRIGGER MOUNTING BRACKET

REVISED 10/2009

SC2 WALL ATTACHMENT OPTIONS SC2-05

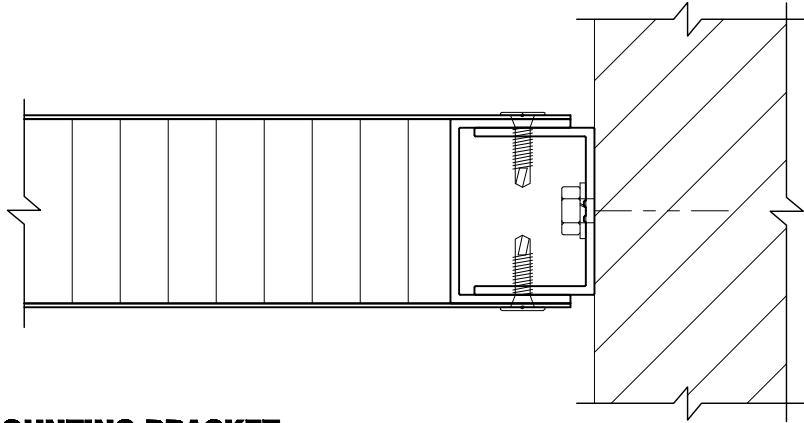

CONCEALED WALL MOUNTING BRACKET

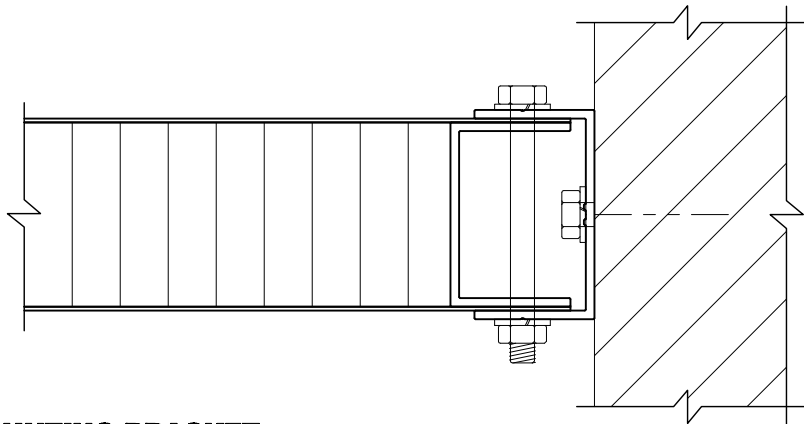

STANDARD WALL MOUNTING BRACKET

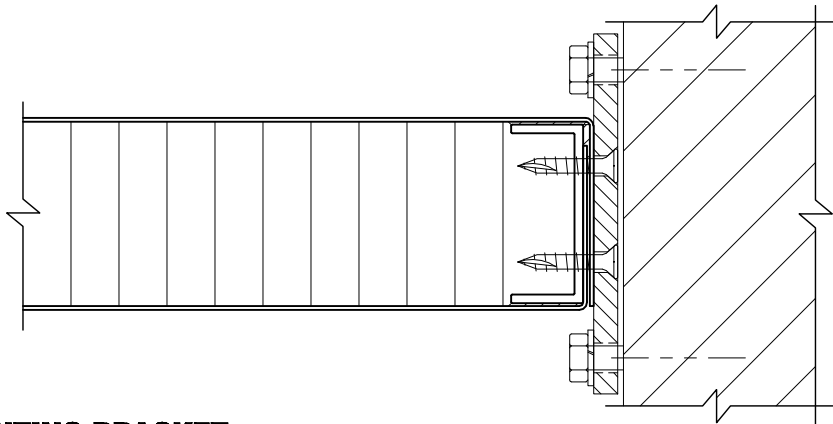

ANGLE WALL MOUNTING BRACKET

REVISED 10/2009

SC2 OUTRIGGER BRACKET OPTIONS SC2-06

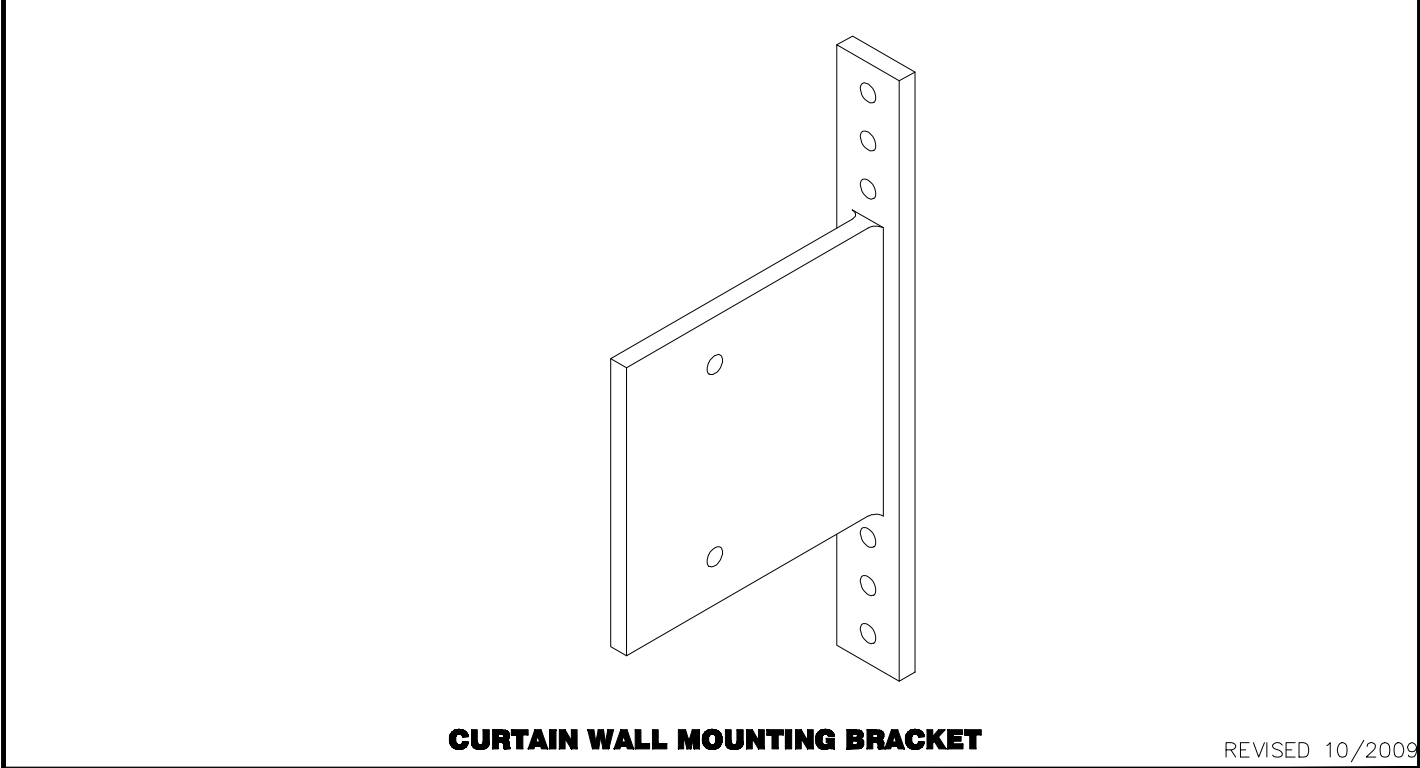
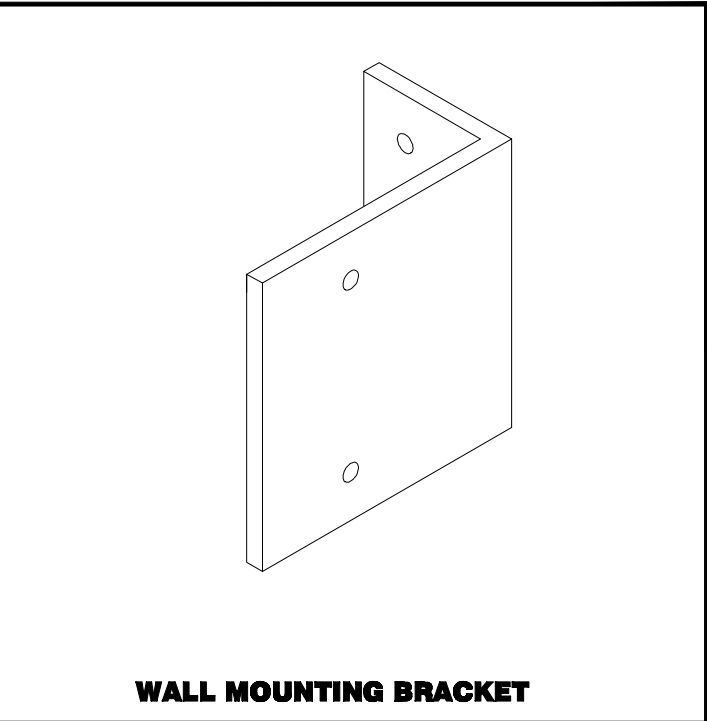
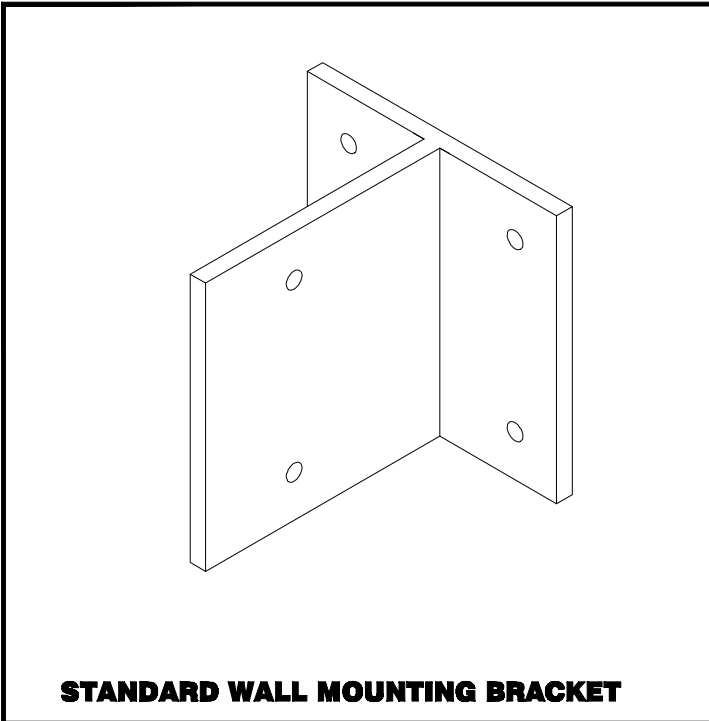

REVISED 10/2009

SC2 WALL ATTACHMENT METHODS

SC2-07

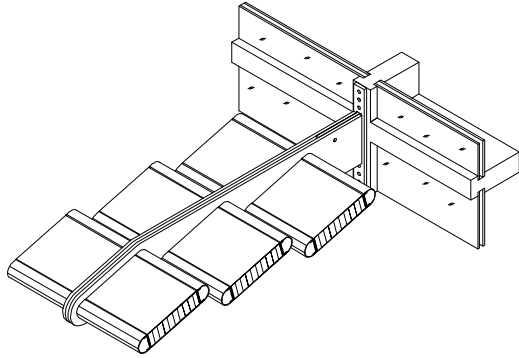

MOUNTING CONDITION AT CURTAIN WALL

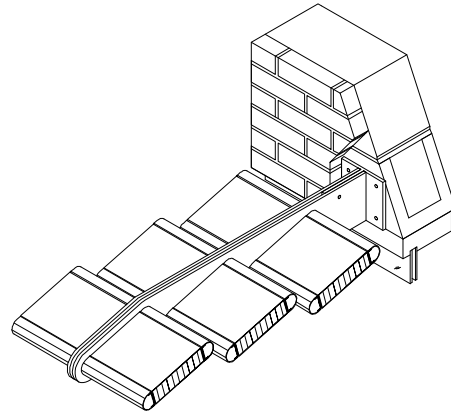

MOUNTING CONDITION AT MASONRY WALL

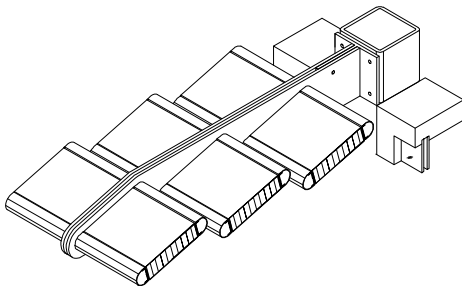

MOUNTING CONDITION AT STRUCTURAL STEEL

REVISED 10/2009



1-800-426-7737

WWW.UNACLAD.COM

Series SC-2

UNA-CLAD Laminated Sunscreen

DESCRIPTION

Exterior laminated aluminum honeycomb screen system. Custom look enhances building's appearance while providing the interior of the building with increased shading from direct sunlight.

FEATURES

- extensive selection of bullnose blade profiles
- longer blade span capabilities than complete extruded sunscreen systems
- angled blades block direct sunlight while allowing rain and snow to pass through easily
- blades may be set to any angle and spaced as specified
- outriggers arm profiles may be customized
- multiple wall attachment options available
- choose from standard offerings or customize sunscreen to your building

MATERIAL OPTIONS

- .375 and .250 inch aluminum outriggers
- .040 and .063 aluminum honeycomb skin blades
- .090 and .125 extruded aluminum bullnose profiles

FINISH OPTIONS

- Kynar 500®/Hylar 5000® high performance fluorocarbon resinous coatings
- class I and II batch anodized

LIMITATIONS

- consult factory for span limitations due to wind load requirements